

BEST 104 BLACK EDITION

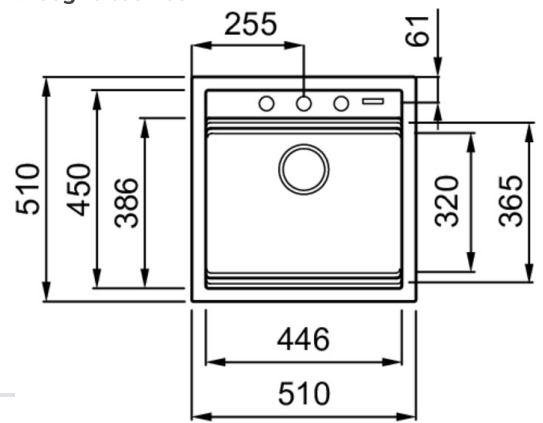

Disegno tecnico



CARATTERISTICHE PRODOTTO

Descrizione	Lavello 1 vasca
Modello	BEST 104 BLACK EDITION
Base (mm)	500 600 se inizio composizione
Installazioni	Sopratop
Dimensioni (mm)	510 x 510
Foro da Incasso (mm)	490 x 480
Profondità Vasca (mm)	200

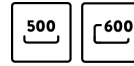

DATI LOGISTICI

Dimensioni Imballo (kg)	690 x 575 x 300
--------------------------------	-----------------

CARATTERISTICHE IMBALLO

Imballo	Cartone e polietilene
----------------	-----------------------

KERATEK^{plus}
CERAMIC NANOTECHNOLOGY CN6



LKB10486BKM K86
8032557029380

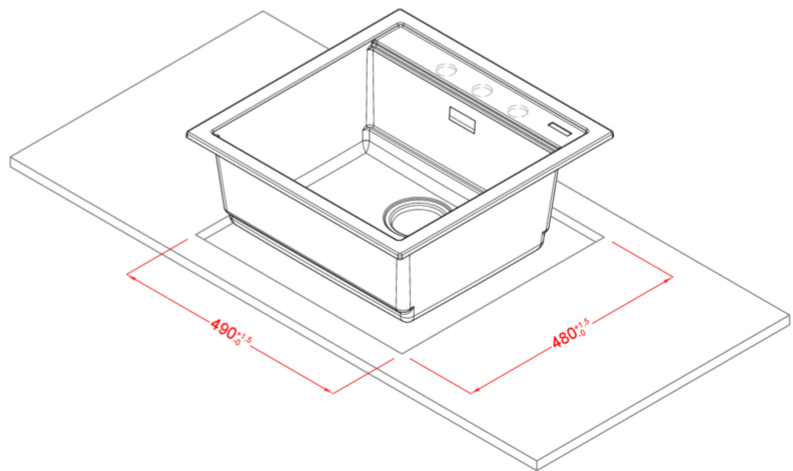
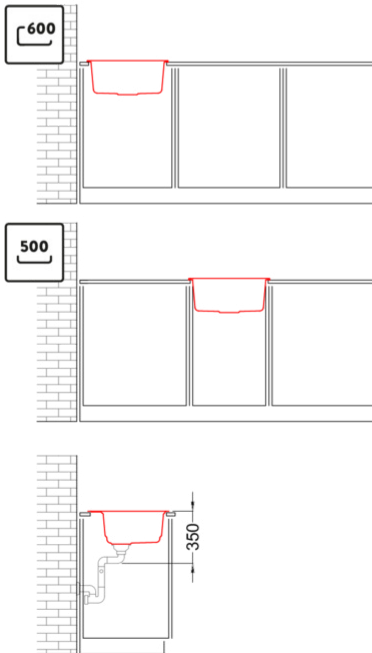
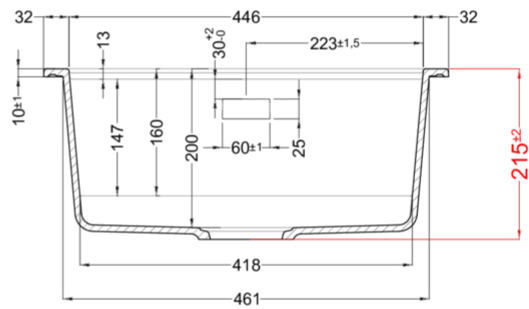
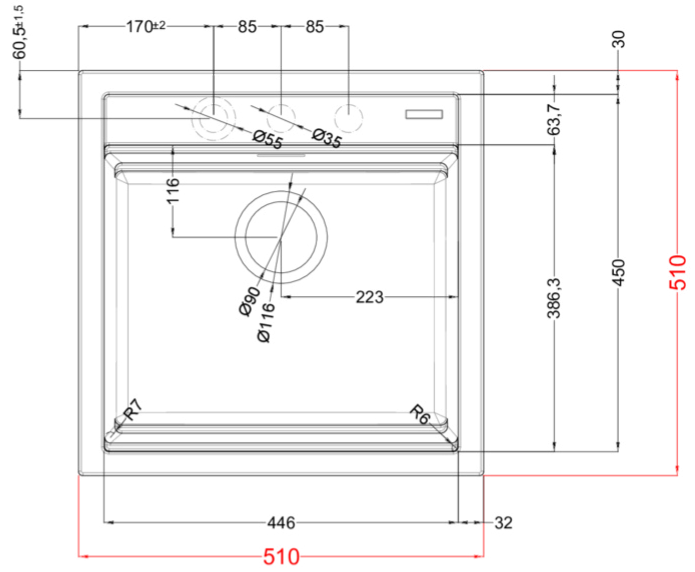
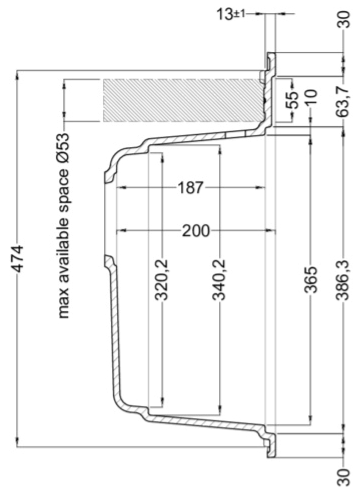

BEST 104

general tolerances where not expressly communicated $\pm 0.2\%$
connection dimensions according to UNI EN 695